

Ideal for:
OEM
Workshops
Assembly Lines

Easy Gripper Workshop 2T

Save
time
Improve
safety



Professional tyre handling tools for workshops and assembly lines

- Unique 3-point grip and turning radius
- Precise rotation +/-25°
- Horizontal/vertical tilt 90°
- Easy and flexible to operate
- Integrated camera system for optimal view
- Prevent damage to tyres, rims & equipment
- Customization available



Experts in Tyre Handling Equipment



Easy Gripper Workshop 2T

A perfect and flexible solution for safe and efficient tyre handling in workshops and at assembly lines with limited space.

The Easy Gripper Workshop 2400-2T can be delivered for installation on your local electrical stacker or as a “READY TO GO” turnkey solution mounted on a rebuild Combilift WR3000.

Capability

Grips, lifts, moves, tilts and rotates tyres from Ø850 - 2.400 mm (34 - 94”) and 2.000 kg (4.400 lbs) at a CoG of 550 mm (22”).

Assembly lines

Grip a tyre/wheel and mount it on a vehicle. Very effective and safe compared to overhead cranes or other solutions – and with less internal damages of painting etc.



Workshops

Solves issues with handling of OTR tyres and wheels, with lift, tilt, rotation and movements in areas with narrow space like workshops.

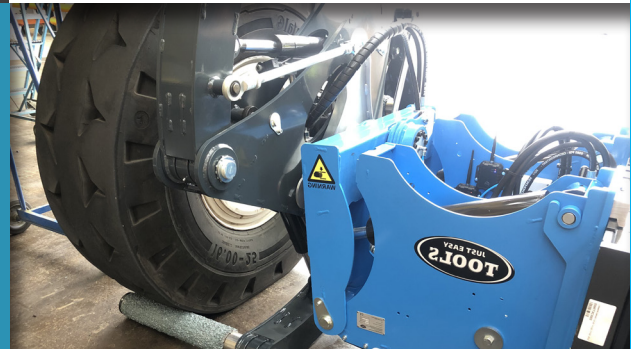

Faster and more accurate

Manual handling and overhead cranes are often slow, potentially dangerous and inaccurate. The Easy Gripper Workshop is a perfect solution.

When moving – the visibility and camera ensure efficient logistics – and when installing, the slow mode and camera option gives the best condition for a fast, safe and accurate installation.

Safer working environment

The Easy Gripper Workshop takes over manual processes of lifting, moving and mounting large tyres – reducing strain and risks for the operator significantly.

The unique 3-point grip, with stone-coated arms, ensures that the Easy Gripper Workshop is in full control of the tyre during the whole process, until it is firmly mounted on a vehicle.



LED working light



Precise 90° tilt, horizontal to vertical



Easy accessible controls + monitoring



Stone-coated pipes ensure a safe grip

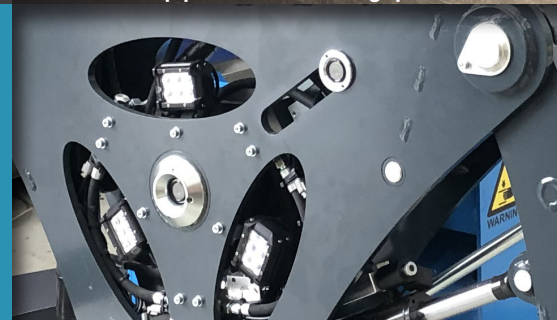

Integrated IR-camera system for optimal view



Flat top arm for limited tyre clearance

Standard features

Unique and safe 3-point grip

Avoid accidents.
Avoid deformation and damages of tyres.
Avoid damages to tyres, rims and equipment.

Integrated camera system for optimal view

With automatic IR function in insufficient light conditions.

Integrated Control System build in tiller

Precise rotation $\pm 25^\circ$

Tilt function 90° , horizontal to vertical

Side Shift $\pm 80\text{mm}^*$

Slow drive mode*

Controlled and accurate movements improve safety.

Turning radius 2.000 mm (79")*

*Depending on carrier.

Optional accessories

Easy shift of gripping pipes for various purposes

Flat top arm for limited tyre clearance.
Telescopic pipes for long reach, to provide room for the tyre fitters and for dual tyre handling.

LED working light

Second camera for view of bolt diameter

Customization on request

Technical Specifications

Lifting capacity:	2.000 kg (4.400 lbs)
Tyre diameter:	850 - 2.400 mm (34 - 94")
Width of Stacker:	2.900 mm (114")
Min. turning radius:	2.000 mm (79")
Tilt from vertical position:	90°
Rotation:	+/-25°

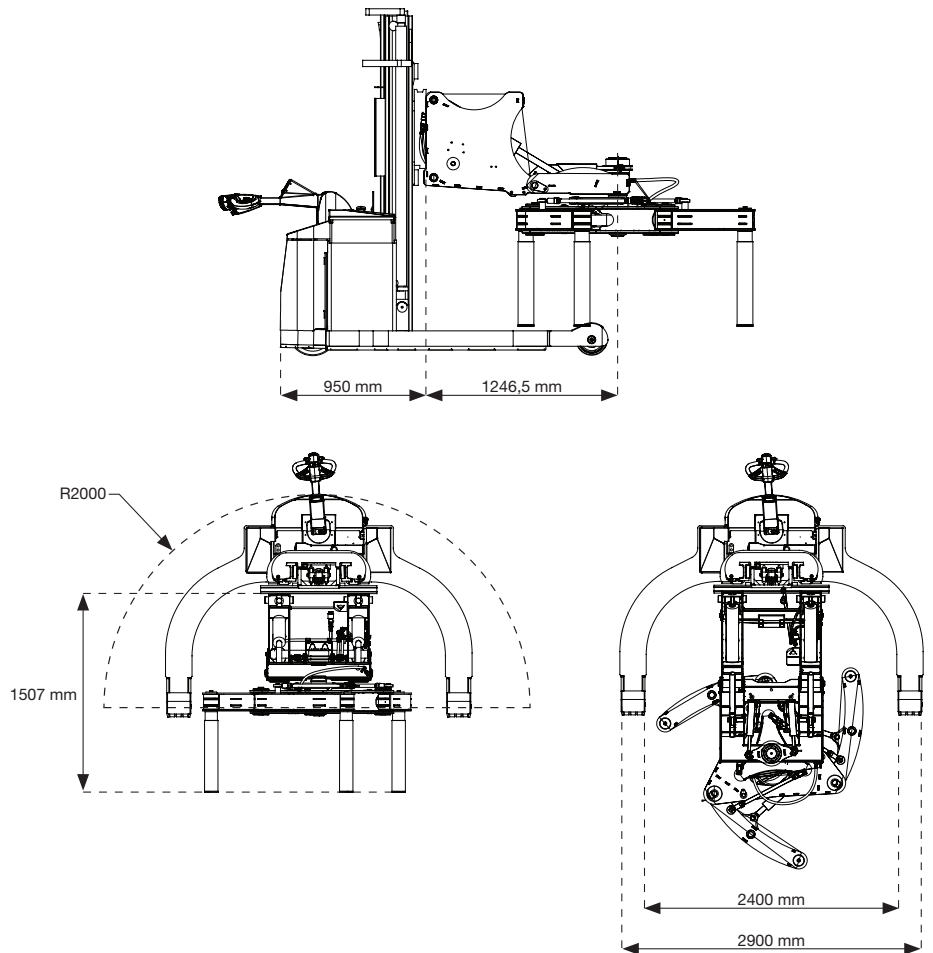

Authorized Dealer

© 2016/2017 Just Easy Tools ApS - Rev. 0.00. 2020



+45 72 344 344
info@justeasytools.dk
www.justeasytools.com
VAT no.: DK33644809

Just Easy Tools ApS
Nupark 51
DK-7500 Holstebro
Denmark